



## ALUMINIUM CAN BODY SPECIFICATION 202/204×408 (Sleek 250ml)

### 1) MATERIAL SPECIFICATION

- (a) Material : Aluminium alloy  
Type 3104
- (b) Temper : H19
- (c) Coil Thickness :  $0.295 \pm 0.005\text{mm}$

### 2) PHYSICAL SPECIFICATION

- (a) Can Height :  $115.00 \pm 0.38\text{mm}$
- (b) Flange Width :  $2.08 \pm 0.25\text{mm}$
- (c) Neck Plug Diameter :  $52.40 \pm 0.25\text{mm}$
- (d) Overflow Capacity :  $270.5 \pm 2.0\text{ml}$

### 3) INTERNAL COATING MATERIAL

Water-Based Modified Epoxy Resin

### 4) MECHANICAL SPECIFICATION

- (a) Internal Pressure Resistance : 610KPa min.
- (b) Axial Column Strength : 0.80KN min.

### 5) PACKING SPECIFICATION

- (a) Cans Per Layer : 506
- (b) Layers Per Pallet : 20
- (c) Cans Per Pallet : 10120
- (d) Net Weight : 99kg Apprx. :
- (e) Gross Weight : 134kg Apprx. :

6) CAN BODY

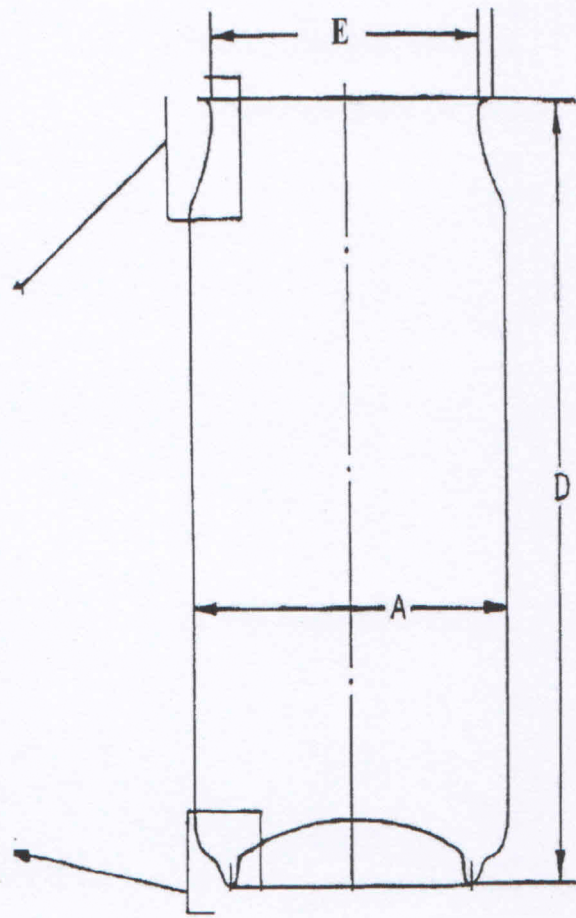
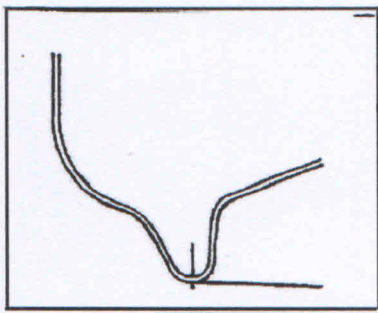
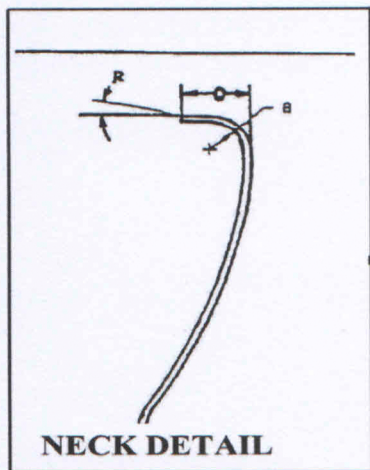

A	57.40mm ref.	D	115.00 ± 0.38mm
B	1.524mm ref.	E	52.40 ± 0.25mm
C	2.08 ± 0.25mm	R	0-12

## 7) PACKING MATERIAL

TOP FRAME

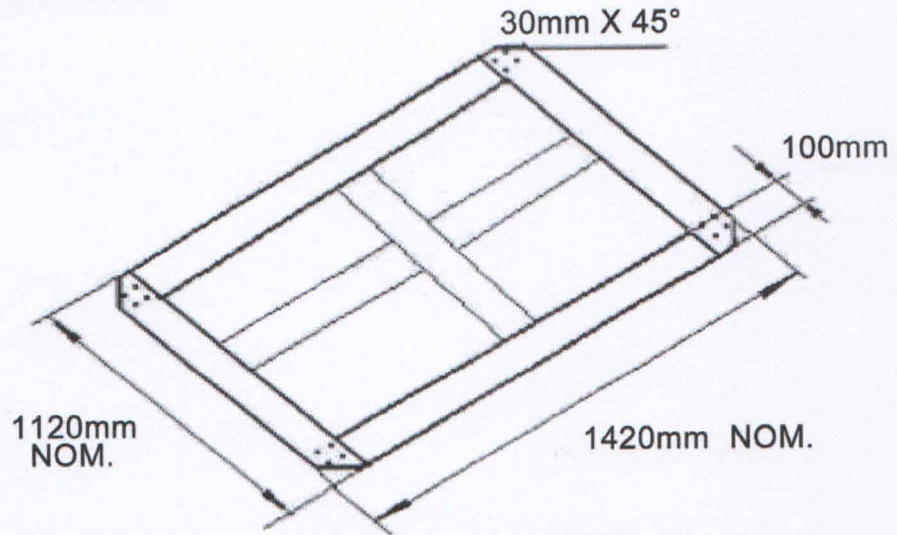

PAPER SHEET LAYER

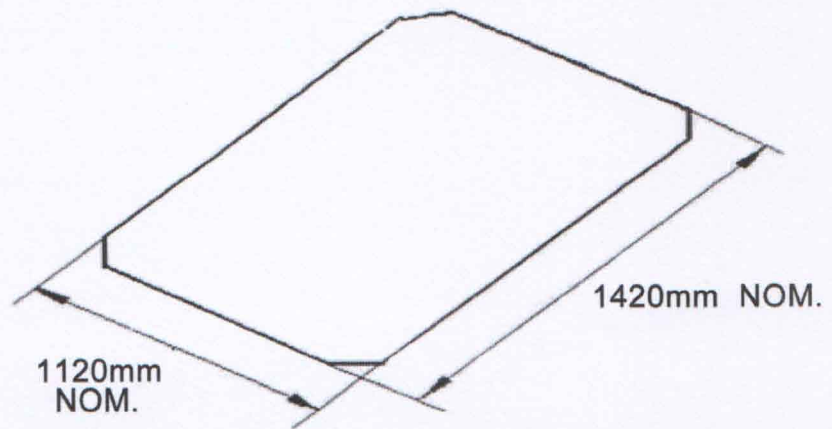

4-WAY PALLET

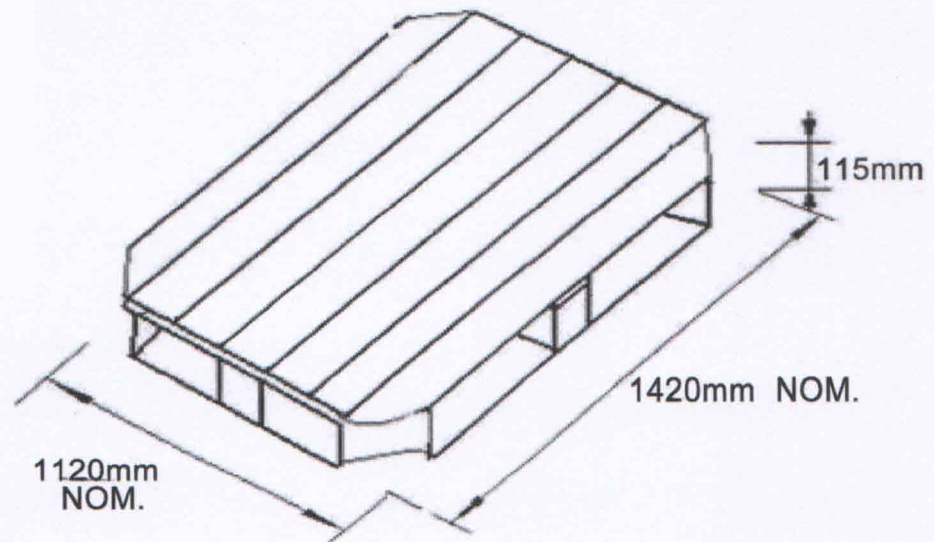

8) CAN BODY COMPRESSION PACK

